

DATA SHEET

100Gb/s QSFP28 CWDM4 Optical Transceiver

Overview

Optical transceiver converts 4 input channels of 25Gb/s electrical data to 4 CWDM optical signals, and multiplexes them into a single channel for 100Gb/s optical transmission. Reversely, on the receiver side, the module optically de-multiplexes a 100Gb/s input into 4 CWDM channels signals, and converts them to 4 channels output electrical data.

Product Features

- Uncooled 4x25Gb/s CWDM transmitter
- QSFP28 MSA compliant
- Supports 103.1Gb/s bit rate
- Compliant with 100G CWDM4 MSA Specification
- Duplex LC connector
- Built-in digital diagnostic functions
- Up to 2km on Single Mode Fiber
- RoHS Compliant
- Operating temperature range: 0°C to 70°C

Applications

- Data Center Interconnect
- 100G Ethernet
- Infiniband QDR and DDR interconnects

General Specifications

Parameter	Symbol	Min	Typ	Max	Unit	Remarks
Bit Error Rate	BER			10 ⁻¹²		
Signaling Rate each Channel			25.78125		Gb/s	
Operating Temperature	T _{OP}	0		70	°C	1
Storage Temperature	T _{STO}	- 40		85	°C	2
Input Voltage	V _{CC}	3.14	3.3	3.46	V	

Notes:

1. Case temperature
2. Ambient temperature

Link Distances

Parameter	Fiber Type	Distance Range (km)
100 Gb/s	9/125um SMF	2

Optical Characteristics – Transmitter

Parameter	Symbol	Min	Typ	Max	Unit	Remarks
Signaling rate, each lane (range)			25.78125		Gb/s	
Total Average Launch Power	P _T			8.5	dBm	
Average Launch Power, Each Lane	P	- 6.5		2.5	dBm	
Optical Center Wavelength	λ ₀	1264.5	1271	1277.5	nm	
	λ ₁	1284.5	1291	1297.5	nm	
	λ ₂	1304.5	1311	1317.5	nm	
	λ ₃	1324.5	1331	1337.5	nm	
Optical Modulation Amplitude, Each Lane	OMA	- 4		2.5	dBm	
Extinction Ratio	ER	3.5			dB	
Side Mode Suppression Ratio	SMSR	30			dB	
Transmitter Dispersion Penalty	TDP			3	dB	
Optical Return Loss Tolerance				20	dB	
Transmitter reflectance				- 12	dB	
Launch Power of OFF Transmitter, per lane	P _{OUT_OFF}			- 30	dBm	

Optical Characteristics – Receiver

Parameter	Symbol	Min	Typ	Max	Unit	Remarks
Signaling rate, each lane (range)			25.78125		Gb/s	
Optical Center Wavelength	λ ₀	1264.5	1271	1277.5	nm	
	λ ₁	1284.5	1291	1297.5	nm	
	λ ₂	1304.5	1311	1317.5	nm	

	λ_3	1324.5	1331	1337.5	nm
Optical Average Input Power, each lane	P_{IN}	- 11.5		2.5	dBm
Optical Modulation Amplitude, Each Lane				2.5	dBm
Damage Threshold	P	3.5			dBm
Receiver Sensitivity (OMA), Each Lane	R_{X_SEN1}			- 10	dBm
Receiver Reflectance	TR_{RX}			- 26	dB
LOS Assert	LOS_A		TBD		dBm
LOS De-Assert	LOS_D		TBD		dBm
LOS Hysteresis			TBD		dB

Electrical Characteristics

Parameter	Symbol	Min	Typ	Max	Unit	Remarks
Power Consumption	P			3.5	W	
Supply Current	I_{CC}			1200	A	

Block Diagram of Transceiver

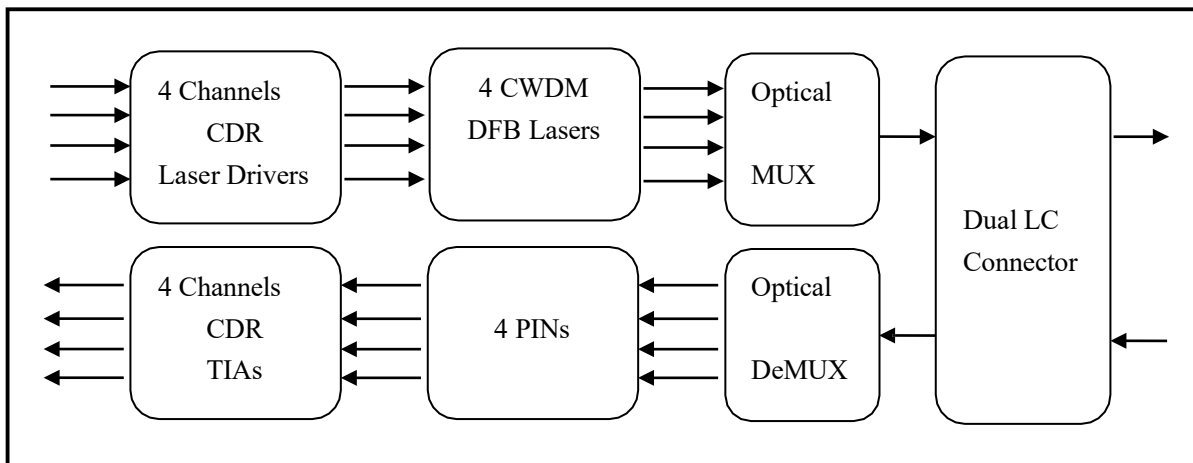

This product converts the 4-channel 25Gb/s electrical input data into CWDM optical signals (light), by a driven 4-wavelength distributed Feedback Laser array. The light is combined by the MUX parts as a 100Gb/s data, propagating out of the transmitter module from the SMF. The receiver module accepts the 100Gb/s CWDM optical signals input, and de-multiplexes it into 4 individual 25Gb/s channels with different wavelength. Each wavelength light is collected by a discrete photo diode, and then outputted as electric data after amplified by a TIA.

Dimensions

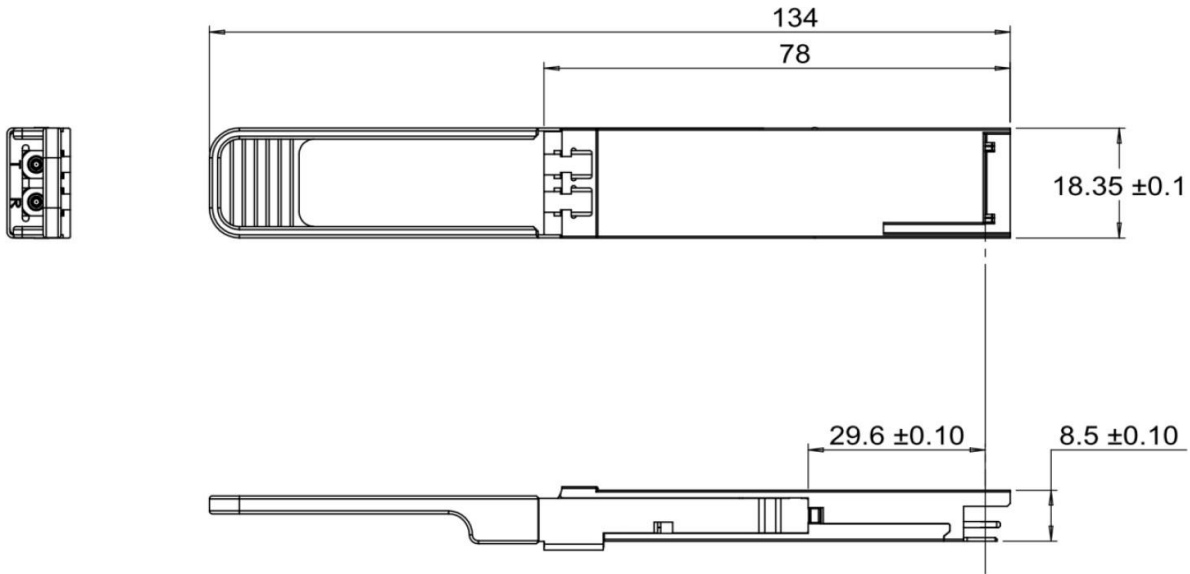

ALL DIMENSIONS ARE ±0.2mm UNLESS OTHERWISE SPECIFIED
UNIT: mm

Electrical Pad Layout

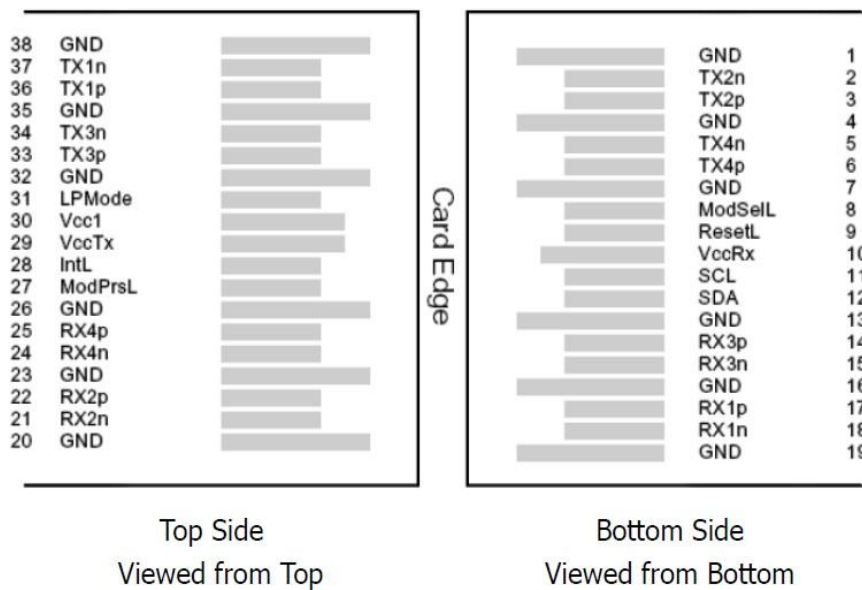

Pin Assignment

PIN #	Symbol	Description	Remarks
1	GND	Ground	
2	Tx2n	Transmitter Inverted Data Input	
3	Tx2p	Transmitter Non-Inverted Data Input	
4	GND	Ground	

5	Tx4n	Transmitter Inverted Data Input
6	Tx4p	Transmitter Non-Inverted Data Input
7	GND	Ground
8	ModSelL	Module Select
9	ResetL	Module Reset
10	V _{cc} Rx	+3.3V Power Supply Receiver
11	SCL	2-wire serial interface clock
12	SDA	2-wire serial interface data
13	GND	Ground
14	Rx3p	Receiver Non-Inverted Data Output
15	Rx3n	Receiver Inverted Data Output
16	GND	Ground
17	Rx1p	Receiver Non-Inverted Data Output
18	Rx1n	Receiver Inverted Data Output
19	GND	Ground
20	GND	Ground
21	Rx2n	Receiver Inverted Data Output
22	Rx2p	Receiver Non-Inverted Data Output
23	GND	Ground
24	Rx4n	Receiver Inverted Data Output
25	Rx4p	Receiver Non-Inverted Data Output
26	GND	Ground
27	ModPrsL	Module Present
28	IntL	Interrupt
29	V _{cc} Tx	+3.3V Power Supply transmitter
30	V _{cc1}	+3.3V Power Supply
31	LPMode	Low Power Mode
32	GND	Ground
33	Tx3p	Transmitter Non-Inverted Data Input
34	Tx3n	Transmitter Inverted Data Input
35	GND	Ground
36	Tx1p	Transmitter Non-Inverted Data Input
37	Tx1n	Transmitter Inverted Data Input
38	GND	Ground

References

1. 100G CWDM4 MSA Specification
2. QSFP28 MSA